



Engineering
Safety &
Productivity



Champ® FMV LED Series Floodlight Fixtures

Leading the way in LED technology
for harsh and hazardous area usage

Champ® FMV LED Series Floodlight Fixtures

High-performance, high-brightness Champ® FMV LED floodlight fixture – brilliantly combining safety, reliability and energy efficiency.

The world's most demanding environments need smart new lighting ideas and innovative approaches to enhancing safety. You need lighting that cuts the overall cost of ownership. Lighting that improves energy efficiency and lives up to ever-escalating environmental standards.

You need all of this innovation from a single source. It could only be: Cooper Crouse-Hinds®.

Introducing ESP solutions.



For more than 100 years, Cooper Crouse-Hinds has exceeded customer expectations when it comes to new ideas and technological advancements.

Today, as the electrical industry's global leader for hazardous environments, we continue to reach

beyond the expected – especially with our commitment to **ESP (Engineering Safety & Productivity)**.

Time to look at LEDs in a whole new light.

Dramatic advances in LED technology have broadened the applicability of this type of illumination, creating an exciting new option for hazardous, industrial and other highly demanding locations. Compared to traditional light sources, LED can deliver longer life, enhanced energy efficiency, greater eco-friendliness, lowered maintenance demands and equal or better quality of light.

Innovative applications for this exciting technology are a natural fit for us, and LED lighting solutions have rapidly become an integral part of our vision.

Traditional HID Floodlight



Champ® FMV LED Floodlight



- Up to 57% more efficient
- Up to 60,000 hours operating life - 2X to 5X the life of typical HID lamps
- Similar footprint to existing floodlights



Application

You're faced with high maintenance and operating costs within your coal-fired power plant. In addition, frequent lamp failures pose a safety concern where continuous lighting is required. You're tasked with identifying a lighting solution that reduces ownership costs and lowers downtime while maintaining similar or improved light levels.

Old Way:

Conventional 400 Watt Probe Start Metal Halide Floodlights are installed throughout the facility and operate continuously. Regular maintenance is required to replace burned-out lamps, which could require scaffolding to be built or other lifting equipment to be rented and can put maintenance personnel into dangerous locations at great heights. According to the Bureau of Labor Statistics, *22% of job related injuries come from workers falling while on the job*. Additionally, any energy that is wasted in operation is lost profit to a power plant.

New Way:

Install 190 Watt Champ® FMV LED Floodlights. Benefit immediately from the long life and energy-efficient LED light source. The Champ LED Floodlight is designed to easily adapt to existing SFA6 and SWB6 slipfitters and wall mount brackets.

Benefit:

Realize a potential \$500K in additional energy savings by making the change to Champ FMV LED. Eliminate the need to build scaffolding, rent bucket trucks, and put your maintenance teams in dangerous situations high above the plant floor in order to change out HID lamps.

The Champ® FMV LED Series is a perfect example of Cooper Crouse-Hinds innovation.

- Enhance safety and productivity
- Cut overall cost of ownership
- Reduce energy consumption
- Meet rising environmental standards

Safe, reliable heat transfer

The heat sink was designed to perform in high ambient temperatures up to +55°C and as low as -40°C. The thick walls of the castings make for a tough, rugged housing that keeps the internal driver and LED temperatures down, allowing them to perform flawlessly, and protects them from damage. Separated driver and LED housing allows dust to shed from fixture.



Installation and replacement made simple

The full-frame yoke was designed to utilize the SFA6 slipfitter and SWB6 wall mount bracket (sold separately), making it ideal for retrofit or new installations. The modular design of the FMV LED allows for easy driver or LED replacement, and allows for the addition of the optional visor or guard in the field. Single cable gland provided with a second plugged cable entry, if an additional cable gland is needed.



High efficiency and lumen output

High efficiency drivers and LED arrays provide reliable low cost operation in **harsh and hazardous environments**. Components were chosen to give industry-leading light output from an LED flood. Replaceable drivers and LEDs for ease of maintenance and “no lights out” feature.



Versatile Design

Suitable for hazardous location use in **gas or dust areas**. Can be used for outdoor or indoor applications, and for a wide range of mounting heights depending on model and light level requirement. Optics were specifically designed to give the familiar and industry-accepted butterfly beam light pattern.



Optional Equipment

Cool (C) and Warm (W) white color temperatures available. Optional visor offered (sold separately) to control light spill. Optional wire guard offered (sold separately) to protect lens from damage. Other options available - consult part numbering guide.

Champ® FMV LED Series Floodlight Fixtures

Champ® FMV LED offers new solutions for old challenges.

It is a new era for Champ® fixtures. This luminaire provides the same durability and reliability of a traditional Champ floodlight, coupled with the efficiency, low cost of ownership, and high performance of a Champ LED fixture. High-performance LEDs and a solid-state electronic driver provide light where you need it, at a fraction of the operating cost of HID technologies.

THE CHAMP FMV LED FAMILY

FMV LED Series Floodlights are designed to provide full-spectrum, crisp, white light. Four versions of the Champ FMV LED are available, providing ideal solutions for a wide range of applications.

FMV Model	Equivalent MH HID Lamp	Energy Savings
FMV 5L	100W - 150W	
FMV 7L	150W - 175W	
FMV 9L	175W - 250W	
FMV 11L	250W - 400W	

LED SYSTEM

- High brightness light emitting diode (LED) arrays
- Color temperature: 3000K (CRI 82) and 5600K (CRI 65) options available
- Advanced heat sink design ensures LED does not exceed manufacturer's temperature ratings across all specified ambient conditions
- LM-80 reports available upon request

APPLICATIONS

- Four lumen outputs allow for installation in numerous mounting heights
- Locations requiring continuous and consistent light levels in extreme ambient temperatures
- Areas requiring frequent on-and-off of lights
- Where flammable vapors, gases, ignitable dusts, fibers or flyings are present; indoors or outdoors
- Where extremely corrosive, wet, dusty, hot and/or cold conditions exist
- Type 4X, marine, wet locations and hose-down environments
- Indoor and outdoor area lighting in plants, buildings, and parking areas
- Manufacturing plants; heavy industrial, chemical, petrochemical or pharmaceutical facilities; platforms; loading docks; outdoor mounted general area lighting



Application

You run a refinery with hazardous and non-hazardous areas. The facility has been in operation for 50 years and has a mix of hazardous rated floodlights from several manufacturers of different types and wattages. You're inventorying a large amount of replacement parts and need to cut back on repair costs while maintaining a safe environment for workers.

Old Way:

Regular maintenance is required to replace burned-out lamps and failed ballasts. You stock several of each type but are finding it hard to purchase some types and are replacing mercury vapor fixtures with metal halide and high pressure sodium. Workers complain about lamp replacement and the color of HPS.

New Way:

Standardize on Champ FMV LED Floodlights and VMV LED Luminaires. When a lamp or ballast gear burns out, replace the complete fixture with the Champ lineup, or retrofit complete areas one at a time. Workers immediately notice the crisp, white light and can more safely and effectively complete their tasks thanks to the "No Lights Out" feature. Energy costs drop instantly.

Benefit:

Inventory decreases tens of thousands of dollars in fixtures and replacements. Your large storage area reduces to only a few drivers on a shelf. Energy usage is cut in half, reducing the plant's energy cost due to lighting from 30% of the overall energy budget down to 15%. Workers are more productive in a safer environment, and less money is wasted on maintenance work so that more money can be spent on the task at hand.

Champ® FMV LED Series Floodlight Fixtures



DRIVERS

Model	5L - 11L
Standard	90-305 VAC, 50/60 Hz; 108-250 VDC
Option 1	347 VAC Model
Option 2	480 VAC Model

CHAMP FMV LED BENEFITS

Enhance safety and productivity

- Instant illumination and restrike
- Better visibility with crisp, white light
- Minimum T4 temperature rating – safely operate in the most hazardous environments and any non-hazardous location
- Cold temperature operation / no warm-up required
- “No lights out” feature – if a single LED fails, others will remain lit from other drivers – minimum 50% output maintained

Reduce operation and maintenance costs

- Easy installation – compact modular fixture attaches onto existing SFA6 and SWB6
- Energy-efficient technology – use up to ½ the power of standard HID luminaires
- Provides up to 60,000 hours rated life – eliminates need for frequent lamp replacement
- Contains no mercury or other hazardous substances

Reliable performance in any environment

- Shock- and vibration-resistant solid-state luminaires have no filaments or glass components that could break – greatly reduces the risk of premature failure
- Operating ambient -40°C to 55°C
- Dark sky friendly with optional visor

STANDARD MATERIALS

- Housing – copper-free aluminum with Corro-free™ epoxy powder coat
- Lens – shatter-resistant glass
- Gaskets – silicone
- External hardware – stainless steel
- Factory-sealed, no external seals required

CERTIFICATIONS & COMPLIANCES

NEC and CEC

- Class I, Division 2, Groups A, B, C, D
- Class I, Zone 2
- Class II, Groups E, F, G (Pending)
- Class III
- Simultaneous Presence
- Wet location, Type 4X, IP66

UL Standards

- UL 844
- UL1598 luminaires, UL1598A marine

CSA Standard

- CSA C22.2 No. 137

IECEx/ATEX

- Ex II 3 G Ex nA II (Pending)
- EN60079-0:2006, EN60079-15:2006 (Pending)
- Ex II 3 D tC A22 IP66 (Pending)
- IEC60079-31: 2008 (Pending)

OPTIONS

Suffix to add to Catalog No.

Fused (only applies to UNV1 model, not available for 347V or 480V; NOT marine or cUL Listed with fusing) **S658**

ACCESSORIES

Catalog No. Sold Separately

Bolt-on visor (sold separately) **DSV1**
 Bolt-on wire guard (sold separately) **P61**
 Floodlight slipfitter (sold separately) **SFA6**
 Slipfitter wall mount adapter (sold separately) **SWB6**

ELECTRICAL RATINGS

	FMV 5L	FMV 7L	FMV 9L	FMV 11L
Voltage Range, VAC	100-277V 50-60 Hz			
	347/480V 60 Hz			
Voltage Range, VDC	108-250	108-250	108-250	108-250
Input Power (Nom.)	64	94	126	188
Input Amps (Max.)	0.550	0.800	1.083	1.608
Power Factor	>0.85	>0.85	>0.85	>0.85

Champ® FMV LED Series Floodlight Fixtures

FMV LED SERIES CATALOG NUMBERING

	FMV	9L	C	Y	/UNV1	76	S658
Series	FMV NEC version with Class/Division ratings						
Light Source / Intensity	5L 100W - 150W equivalent 7L 150W - 175W equivalent 9L 175W - 250W equivalent 11L 250W - 400W equivalent						
Color Temperature	C 5600K (cool white) W 3000K (warm white)						
Mounting	Y Yoke						
Voltage	/UNV1 100 VAC to 277 VAC 50/60 Hz, 108 VDC to 250 VDC /347 347 VAC 60 Hz /480 480 VAC 60 Hz						
Optical Distribution	BLANK No optics 76 Floodlight pattern optics included						
Suffixes	S658 Fused; for UNV1 only; not for marine or cUL						
Additional Items (Sold Separately)							
DSV1	DSV dark sky visor						
P61	Wire guard factory installed						
SFA6	Floodlight slipfitter						
SWB6	Slipfitter wall mount adapter						

DIMENSIONS

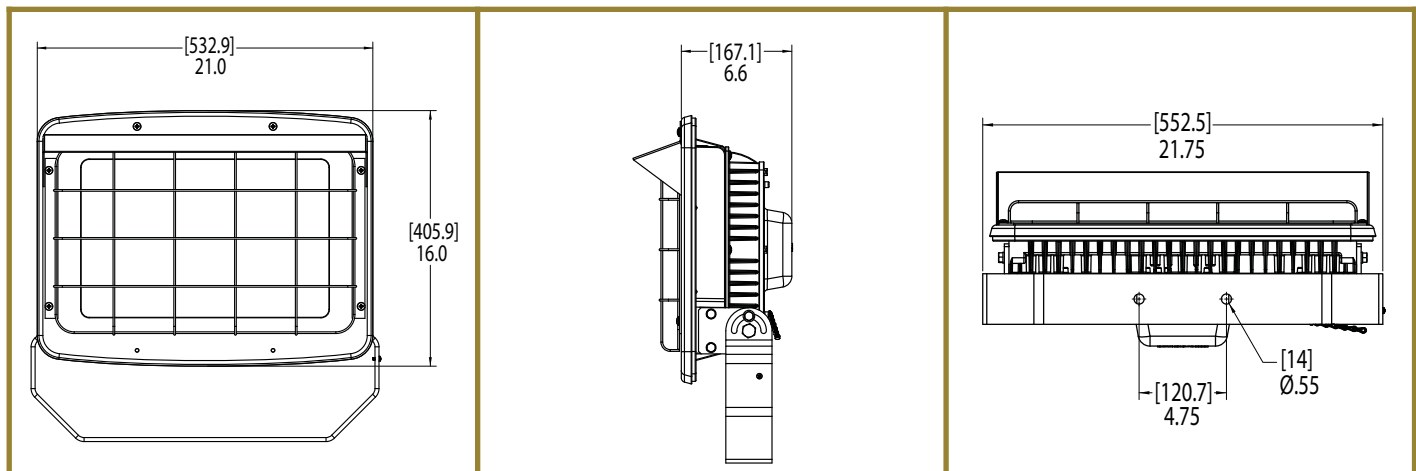

Champ® FMV LED Series Floodlight Fixtures

COOPER Crouse-Hinds



PHOTOMETRIC DATA

**FMV11L @ 30 Ft. High; Tilt Angle = 45 Degrees
(Isofootcandles)**

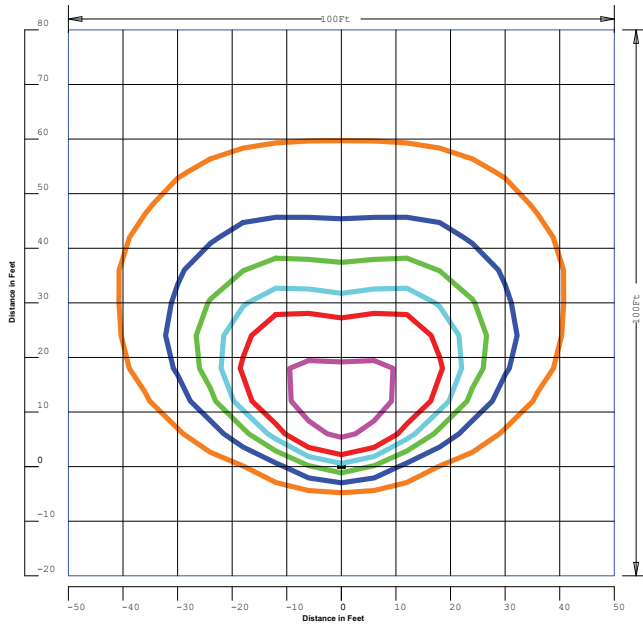

MULTIPLIERS FOR OTHER LED FLOODLIGHTS

Luminaire Series	Lumen Multiplier	Lumens*
FMV 5L	0.33	3160
FMV 7L	0.50	4740
FMV 9L	0.67	6320

*FMV 11L output is 9481.

AMBIENT TEMPERATURE

	MAX. TEMP. °C	CL. I, DIV. 2	CL. II, DIV. 1 & 2 / CL. III / SIMU. PRESENCE	CL. I, ZONE 2
FMV 5L	40	T4	Pending	T4
	55	T4	Pending	T4
FMV 7L	40	T4	Pending	T4
	55	T4	Pending	T4
FMV 9L	40	T4	Pending	T4
	55	T4	Pending	T4
FMV 11L	40	T4	Pending	T4
	55	T4	Pending	T4

WEIGHTS

MODEL	LBS.
5L	39.11
7L	39.16
9L	39.73
11L	40.35

